

INDICE

PUNTE DA TRAPANO COBALTO.....	2
PUNTE DA TRAPANO SPEEDMASTER RETTIFICATE.....	3
PUNTE DA TRAPANO RETTIFICATE.....	4
PUNTE DA TRAPANO RULLATE.....	5
FRESE CONICHE.....	6
FRESE ROTATIVE.....	7
MASCHI.....	8
FILIERE.....	9
GIRAMASCHI E FILIERE.....	11
KIT RIPRISTINO FILETTATURE DANNEGGIATE.....	12
ASSORTIMENTO MASCHI E FILIERE.....	13
DISCHI DA TAGLIO E SMERIGLIO.....	14
TELE.....	15
SMERIGLIO RUOTE LAMELLARI E DISCHI FIBRATI.....	15
DISCHI LAMELLARI.....	17
DISCHI RESINATI CON VELCRO.....	19
MOLE ROTATIVE AL CORINDONE NOBILE.....	20
MANICOTTI MOLE DA BANCO / LAME BIMETALLICHE.....	21
SPAZZOLE IN ACCIAIO CON GAMBO E CIRCOLARI.....	22

PUNTE DA TRAPANO COBALTO

PUNTE ELICOIDALI AL COBALTO 5% INTERAMENTE RETTIFICATA

	Ø mm	LUNGHEZZA	ARTICOLO
	1	34mm	
1.5	40mm		AM1102.2
2	49mm		AM1103.2
2.5	57mm		AM1104.2
3	61mm		AM1105.2
3.5	70mm		AM1107.2
4	75mm		AM1108.2
4.5	80mm		AM1109.2
5	86mm		AM1111.2
5.5	93mm		AM1112.2
6	93mm		AM1113.2
6.5	101mm		AM1114.2
7	109mm		AM1116.2
7.5	109mm		AM1117.2
8	117mm		AM1118.2
8.5	117mm		AM1120.2
9	125mm		AM1122.2
9.5	125mm		AM1123.2
10	133mm		AM1124.2
10.5	142mm		AM1125.2
11	142mm		AM1126.2
11.5	142mm		AM1127.2
12	151mm		AM1128.2
12.5	151mm		AM1129.2
13	151mm		AM1130.2



ASSORTIMENTO PUNTE AL COBALTO 5%

	Ø mm	N° PEZZI	ARTICOLO
	1:10 x 0.5	19	AM1130.30

ASSORTIMENTO PUNTE AL COBALTO 5%

	Ø mm	N° PEZZI	ARTICOLO
	1:13 x 0.5	25	AM1130.40

ASSORTIMENTO PUNTE AL COBALTO 5%

	N° PEZZI	ARTICOLO
	128	AM1130.50

COMPOSIZIONE

Ø mm	N° PEZZI	Ø mm	N° PEZZI	Ø mm	N° PEZZI
1	10	5.5	3	10	2
1.5	10	6	3	10.5	2
2	10	6.5	3	11	2
2.5	10	7	3	11.5	2
3	10	7.5	3	12	2
3.5	10	8	3	12.5	2
4	10	8.5	2	13	2
4.5	10	9	2		
5	10	9.5	2		

PUNTE AL COBALTO 5% INTERAMENTE RETTIFICATE CON CODOLO RIBASSATO

	Ø mm	LUNGHEZZA	ARTICOLO
	10.5	130mm	
11	142mm		AM1126.5
11.5	142mm		AM1127.5
12	151mm		AM1128.5
12.5	151mm		AM1129.5
13	151mm		AM1130.5
13.5	160mm		AM1134.5
14	160mm		AM1131.5
14.5	169mm		AM1135.5
15	169mm		AM1132.5
15.5	178mm		AM1133.5
16	178mm		AM1136.5



CARATTERISTICHE

Punte con ottima resistenza alle sollecitazioni termiche, adatte per forare acciai legati e non con resistenza fino a 1200n/mm² in modo particolare acciai di bonifica, acciai per lavorazioni a caldo e a freddo, acciai inossidabili e ghisa.

PUNTE DA TRAPANO SPEEDMASTER RETTIFICATE

PUNTE ELICOIDALI RETTIFICATE A DOPPIO CONOIDE "SPEEDMASTER"

	Ø mm	LUNGHEZZA	ARTICOLO
	1	34mm	AM1101.3
	1.5	40mm	AM1102.3
	2	49mm	AM1103.3
	2.5	57mm	AM1104.3
	3	61mm	AM1105.3
	3.5	70mm	AM1107.3
	4	75mm	AM1108.3
	4.5	80mm	AM1109.3
	5	86mm	AM1111.3
	5.5	93mm	AM1112.3
	6	93mm	AM1113.3
	6.5	101mm	AM1114.3
	7	109mm	AM1116.3
	7.5	109mm	AM1117.3
	8	117mm	AM1118.3
	8.5	117mm	AM1119.3
	9	125mm	AM1120.3
	9.5	125mm	AM1121.3
	10	133mm	AM1122.3
	10.5	142mm	AM1123.3
	11	142mm	AM1124.3
	11.5	142mm	AM1125.3
	12	151mm	AM1126.3
	12.5	151mm	AM1127.3
	13	151mm	AM1128.3



AISI M2
HV= 820+850

3 planeti antistruciolo (Ø > 5 mm):
Piena trasmissione della potenza



Cave ampie e lisce:
Facile estrazione dei trucioli

Alfatura speciale

ASSORTIMENTO PUNTE "SPEEDMASTER" DALL 1 mm AL 10 mm

	Ø mm	N° PEZZI	ARTICOLO
 <p>Abs</p> <p>GIOMACAR</p> <p>19 pcs Ø 1÷10 x 0,5 mm</p>	1:10 x 0.5	19	AM1130.70

ASSORTIMENTO PUNTE "SPEEDMASTER" DALL 1 mm AL 13 mm

	Ø mm	N° PEZZI	ARTICOLO
 <p>GIOMACAR</p> <p>25 pcs Ø 1÷13 x 0,5 mm</p>	1:13 x 0.5	25	AM1130.71

CARATTERISTICHE



Taglio altamente professionale con trapani portatili o stazionari, in acciai legati ed altamente legati, acciaio inox, fino a R ≤ 900N/mm².2, ferro, alluminio, metalli.

PUNTE DA TRAPANO RETTIFICATE

PUNTE ELICOIDALI CILINDRICHE INTERAMENTE RETTIFICATE FINITURA BRILLANTE

	Ø mm	LUNGHEZZA	ARTICOLO
		1	34mm
	1.5	40mm	AM1102.1
	2	49mm	AM1103.1
	2.5	57mm	AM1104.1
	3	61mm	AM1105.1
	3.5	70mm	AM1107.1
	4	75mm	AM1108.1
	4.5	80mm	AM1109.1
	5	86mm	AM1111.1
	5.5	93mm	AM1112.1
	6	93mm	AM1113.1
	6.5	101mm	AM1114.1
	7	109mm	AM1116.1
	7.5	109mm	AM1117.1
	8	117mm	AM1118.1
	8.5	117mm	AM1120.1
	9	125mm	AM1122.1
	9.5	125mm	AM1123.1
	10	133mm	AM1124.1
	10.5	142mm	AM1125.1
	11	142mm	AM1126.1
	11.5	142mm	AM1127.1
	12	151mm	AM1128.1
	12.5	151mm	AM1129.1
	13	151mm	AM1130.1

PUNTE ELICOIDALI CILINDRICHE INTERAMENTE RETTIFICATE FINITURA BRILLANTE CODOLO RIDOTTO

	Ø mm	LUNGHEZZA	ARTICOLO
	Ø 10 mm.	10.5	130mm
	11	142mm	AM1126.4
d=10 mm.	11.5	142mm	AM1127.4
	12	151mm	AM1128.4
	12.5	151mm	AM1129.4
	13	151mm	AM1130.4
	13.5	160mm	AM1134.4
	14	160mm	AM1131.4
	14.5	169mm	AM1135.4
	15	169mm	AM1132.4
	15.5	178mm	AM1133.4
	16	178mm	AM1136.4

ASSORTIMENTI PUNTE ELICOIDALI CILINDRICHE

	Ø mm	N° PEZZI	ARTICOLO
	1:10 x 0.5	19	AM1130.96

	Ø mm	N° PEZZI	ARTICOLO
	1:13 x 0.5	25	AM1130.97

	Ø mm	N° PEZZI	ARTICOLO
	1:13 x 0.5	168	AM1130.99

COMPOSIZIONE

Ø mm	N° PEZZI	Ø mm	N° PEZZI	Ø mm	N° PEZZI
1	10	5.5	5	10	5
1.5	10	6	5	10.5	3
2	10	6.5	5	11	3
2.5	10	7	5	11.5	3
3	20	7.5	5	12	3
3.5	10	8	5	12.5	3
4	10	8.5	5	13	3
4.5	10	9	5		
5	10	9.5	5		

CARATTERISTICHE

Taglio di materiali con $R \leq 800 \text{ N/mm}^2$ quali acciai legati, ghisa, tutti i metalli in genere, la grafite. Precisione di foratura e costanza di rendimenti elevati

PUNTE DA TRAPANO RULLATE

PUNTE ELICOIDALI CILINDRICA RULLATA

	Ø mm	LUNGHEZZA	ARTICOLO
		1	34mm
	1.5	40mm	AM1102
	2	49mm	AM1103
	2.5	57mm	AM1104
	3	61mm	AM1105
	3.5	70mm	AM1107
	4	75mm	AM1108
	4.5	80mm	AM1109
	5	86mm	AM1111
	5.5	93mm	AM1112
	6	93mm	AM1113
	6.5	101mm	AM1114
	7	109mm	AM1116
	7.5	109mm	AM1117
	8	117mm	AM1118
	8.5	117mm	AM1120
	9	125mm	AM1122
	9.5	125mm	AM1123
	10	133mm	AM1124
	10.5	142mm	AM1125
	11	142mm	AM1126
	11.5	142mm	AM1127
	12	151mm	AM1128
	12.5	151mm	AM1129
	13	151mm	AM1130



ASSORTIMENTI PUNTE ELICOIDALI RETTIFICATE

	Ø mm	N° PEZZI	ARTICOLO
 19 pcs Ø 1÷10 x 0,5 mm	1:10 x 0,5	19	AM1131.21

	Ø mm	N° PEZZI	ARTICOLO
 25 pcs Ø 1÷13 x 0,5 mm	1:13 x 0,5	25	AM1131.22

	Ø mm	N° PEZZI	ARTICOLO
 19 pcs HSS Ø 1÷10 x 0,5 mm	1:10 x 0,5	19	AM1131.20

	Ø mm	N° PEZZI	ARTICOLO
 Metal 497x266x59	1:13 x 0,5	168	AM1131.23

COMPOSIZIONE

Ø mm	N° PEZZI	Ø mm	N° PEZZI	Ø mm	N° PEZZI
1	10	5.5	5	10	5
1.5	10	6	5	10.5	3
2	10	6.5	5	11	3
2.5	10	7	5	11.5	3
3	20	7.5	5	12	3
3.5	10	8	5	12.5	3
4	10	8.5	5	13	3
4.5	10	9	5		
5	10	9.5	5		

PUNTE ELICODALI RULLATE CODOLO RIDOTTO

	Ø mm	LUNGHEZZA	ARTICOLO
	10.5	130mm	AM1125.6
	11	142mm	AM1126.6
	11.5	142mm	AM1127.6
	12	151mm	AM1128.6
	12.5	151mm	AM1129.6
	13	151mm	AM1130.6
	13.5	160mm	AM1134.6
	14	160mm	AM1131.6
	14.5	169mm	AM1135.6
	15	169mm	AM1132.6
	15.5	178mm	AM1133.6
	16	178mm	AM1136.6



CARATTERISTICHE

Punte per forare tutti i tipi di metalli, ferro, acciaio.

FRESE CONICHE

FRESE AD INCASSARE E SVASARE A 3 TAGLI

	FRESA Ø mm	LUNGHEZZA GAMBO	GAMBO Ø mm	ARTICOLO
	6,3	45	5	AM1137.1
	8,3	50	6	AM1137.2
	10,4	50	6	AM1137.3
	12,4	56	8	AM1137.4
	16,5	60	10	AM1137.6
20,5	63	10	AM1137.61	

ASSORTIMENTO 6 FRESE

	FRESA Ø mm	LUNGHEZZA GAMBO	GAMBO Ø mm	ARTICOLO
	6,3	45	5	AM1137
	8,3	50	6	
	10,4	50	6	
	12,4	56	8	
	16,5	60	10	
20,5	63	10		

FRESE A GRADINI IN HSS-G PER FORARE E ALLARGARE FORI SU LAMIERE

	CODICE	FRESA Ø mm	GAMBO Ø mm	LUNGHEZZA mm	ARTICOLO
	2	4 + 12	6	70	AM1137.7
	4	4 + 20	10	85	AM1137.8
6	4 + 30	10	97	AM1137.9	

ASSORTIMENTO FRESE A GRADINI

	CODICE	Ø mm	N° PEZZI	ARTICOLO
	2	4 + 12	1	AM1137.91
	4	4 + 20	1	
6	4 + 30	1		

FRESE ROTATIVE

FRESE ROTATIVE IN HSS



	TAGLIO	FRESA Ø mm	GAMBO Ø mm	LUNGHEZZA mm	ARTICOLO
	BASTARDA	12X30	6	70	AM1137.92
	1/2 DOLCE	12x30	6	70	AM1137.93

	TAGLIO	FRESA Ø mm	GAMBO Ø mm	LUNGHEZZA mm	ARTICOLO
	BASTARDA	12X30	6	70	AM1137.94
	1/2 DOLCE	12x30	6	70	AM1137.95

	TAGLIO	FRESA Ø mm	GAMBO Ø mm	LUNGHEZZA mm	ARTICOLO
	BASTARDA	12	6	70	AM1137.96
	1/2 DOLCE	12	6	70	AM1137.97

	TAGLIO	FRESA Ø mm	GAMBO Ø mm	LUNGHEZZA mm	ARTICOLO
	1/2 DOLCE	12x30	6	70	AM1137.98
					

	TAGLIO	FRESA Ø mm	GAMBO Ø mm	LUNGHEZZA mm	ARTICOLO
	1/2 DOLCE	12x30	6	70	AM1137.99
					

	DESCRIZIONE	ARTICOLO
	ASSORTIMENTO 5 FORME TAGLIO 1/2 DOLCE - DIAMETRO 12	AM1137.999
		

CARATTERISTICHE



HSS

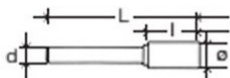

ACCIAIO



ALLUMINIO



CANALINE
ZINCATE



Taglio bastardo per leghe leggere: rame, ottone, bronzo, acciaio dolce.

Velocità consigliata 200 / 250 m/min.



Taglio mezzo dolce per acciai, ghisa.

Velocità consigliata 80 / 220 m/min.

MASCHI

MASCHI A MANO SERIE 3 PEZZI FILETTATURA ISO PASSO GROSSO



Ø X PASSO mm	ARTICOLO
1,0X0,25	MF1000
1,1X0,25	MF1001
1,2X0,25	MF1002
1,4X0,3	MF1003
1,6X0,35	MF1004
1,7X0,35	MF1005
1,8X0,35	MF1006
2,0X0,4	MF1007
2,2X0,45	MF1008
2,3X0,4	MF1009
2,5X0,45	MF1010
2,6X0,45	MF1011
3,0X0,5	MF1012
3,5X0,6	MF1013
4,0X0,7	MF1014
4,5X0,7	MF1015
5,0X0,8	MF1016
5,5X0,9	MF1017
6,0X1	MF1018
7,0X1	MF1019
8,0X1,25	MF1020
9,0X1,25	MF1021
10X1,5	MF1022
11X1,5	MF1023
12X1,75	MF1024
14X2	MF1025
16X2	MF1026
18X2,5	MF1027
20X2,5	MF1028
22X2,5	MF1029
24X3	MF1030
27X3	MF1031
30X3,5	MF1032
33x3,5	MF1033

MASCHIO A MANOO SERIE 2 PEZZI FILETTATURA ISO PASSO FINE



Ø X PASSO mm	ARTICOLO
8X1	MF1044
10X1	MF1045
10X1,25	MF1046
12X1,25	MF1047
12X1,5	MF1048
14X1,5	MF1049
16X1,5	MF1050
18X1,5	MF1051
20X1,5	MF1052
22X1,5	MF1053
24X2	MF1054
26x2	MF1055
27x2	MF1056
28x2	MF1057
30x2	MF1058

MASCHIO A MANO FINITORE FILETTATURA ISO PASSO GROSSO



Ø X PASSO mm	ARTICOLO
3X0,5	MF1058.1
4X0,7	MF1058.2
5X0,8	MF1058.3
6X1	MF1058.4
8X1,25	MF1058.5
10X1,5	MF1058.6
12X1,75	MF1058.7
14X2	MF1058.8
16X2	MF1058.9
18X2	MF1058.90
20x2	MF1058.91

CARATTERISTICHE



ACCIAIO METALLI ALLUMINIO

Per filettature di fori passanti in acciaio da costruzione, acciaio da bonifica, materiali in genere sino a $R \leq 800 \text{ N/mm}^2$

FILIERE

FILIERE TONDE AD IMBOCCO CORRETTO FILETTATURA METRICA ISO A PASSO GROSSO

Ø X PASSO mm	ARTICOLO	Ø X PASSO mm	ARTICOLO
1,4X0,3	MF1077	8,0X1,25	MF1094
1,6X0,35	MF1078	9,0X1,25	MF1095
1,7X0,35	MF1079	10X1,5	MF1096
1,8X0,35	MF1080	11X1,5	MF1097
2,0X0,4	MF1081	12X1,75	MF1098
2,2X0,45	MF1082	14X2	MF1099
2,3X0,4	MF1083	16X2	MF1100
2,5X0,45	MF1084	18X2,5	MF1101
2,6X0,45	MF1085	20X2,5	MF1102
3,0X0,5	MF1086	22X2,5	MF1103
3,5X0,6	MF1087	24X3	MF1104
4,0X0,7	MF1088	27X3	MF1105
4,5X0,75	MF1089	30X3,5	MF1106
5,0X0,8	MF1090	33X3,5	MF1107
5,5X0,9	MF1091	36X4	MF1108
6,0X1	MF1092	39X4	MF1109
7,0X1	MF1093	42X4,5	MF1110

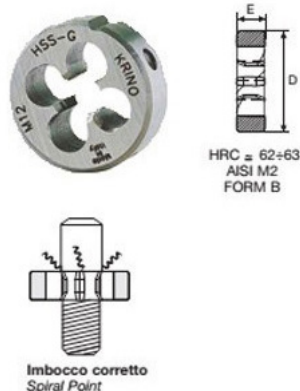

FILIERE TONDE AD IMBOCCO CORRETTO FILETTATURA METRICA ISO A PASSO FINE

Ø x PASSO mm	MISURE D x E mm	ARTICOLO
8X1	25X9	MF1059
10X1	30X11	MF1060
10X1,25	30X11	MF1061
12X1,25	38X10	MF1062
12X1,5	38X10	MF1063
14X1,5	38X10	MF1064
16X1,5	45X14	MF1065
18X1,5	45X14	MF1066
20X1,5	45X14	MF1067
22X1,5	55X16	MF1068
24X2	55X16	MF1069
26X2	55X16	MF1070
27X2	65X18	MF1071
28X2	65X18	MF1072
30X2	65X18	MF1073



SET MASCHI CON ATTACCO ESAGONALE

	Ø FILETTO	LUNGHEZZA mm	ESAGONO POLLICI mm	ARTICOLO
	3X0,5	36	1/4" ÷ 6,3	MF1158.30
	4X0,7	39		
	5X0,8	41		
	6X1	44		
	8X1,25	50		
	10X1,5	59		
CARATTERISTICHE SET DI UTENSILI CON ATTACCO ESAGONALE PER AVVIATORI E TRAPANI REVERSIBILI				

MASCHI CON ATTACCO ESAGONALE

 <p>METALLI ALLUMINIO PLASTICA</p>	Ø FILETTO	LUNGHEZZA mm	ESAGONO POLLICI mm	ARTICOLO
	3X0,5	36	1/4" ÷ 6,3	MF1158.20
	4X0,7	39		MF1158.21
	5X0,8	41		MF1158.22
	6X1	44		MF1158.23
	8X1,25	50		MF1158.24
	10X1,5	59		MF1158.25
CARATTERISTICHE UTENSILI PER AVVIATORI E TRAPANI REVERSIBILI, PER FORARE, FILETTARE E SVASARE IN ACCIAIO, ALLUMINIO, METALLI NON FERROSI IN GENERE, PLASTICA.				

PORTAFILIERE PER FILIERE TONDE

	Ø FILETTO mm	MISURE FILIERE mm	ARTICOLO
	1 ÷ 2,6	16 X 5	MF1131
	3 ÷ 4	20 X 5	MF1131.1
	4,5 ÷ 6	20 X 7	MF1131.2
	7 ÷ 9	25 X 9	MF1131.3
	10 ÷ 11	30 X 11	MF1131.4
	12 ÷ 4	38 X 14	MF1131.5
	16 ÷ 20	45 X 18	MF1132
	22 ÷ 24	55 X 22	MF1133
	27 ÷ 36	65 X 25	MF1134
	38 ÷ 42	75 X 20	MF1135
39 ÷ 42	75 X 30	MF1136	

GIRAMASCHI E FILIERE

GIRAMASCHI ESTENDIBILE MODELLO AMERICANO

	Ø FILETTO mm	MISURE MASCHIO mm	ARTICOLO
	1 ÷ 8	0	MF1122
	1 ÷ 10	1	MF1123
	1 ÷ 12	1.1/2	MF1124
	4 ÷ 12	2	MF1125
	5 ÷ 12	3	MF1126
	11 ÷ 27	4	MF1127
	13 ÷ 32	5	MF1128
	18 ÷ 42	6	MF1129
	25 ÷ 52	7	MF1130
25 ÷ 64	8	MF1131	

GIRAMASCHI A CRICCHETTO REVERSIBILE CORTO

	Ø FILETTO mm	MISURE FILIERE mm	ARTICOLO
	3 ÷ 10	85	MF1118
	5 ÷ 12	100	MF1119

GIRAMASCHI A CRICCHETTO REVERSIBILE LUNGO

	Ø FILETTO mm	MISURE FILIERE mm	ARTICOLO
	3 ÷ 10	250	MF1120
	5 ÷ 12	300	MF1121

KIT RIPRISTINO FILETTATURE DANNEGGIATE

FILIERE TONDE AD IMBOCCO CORRETTO FILETTATURA METRICA ISO A PASSO FINE

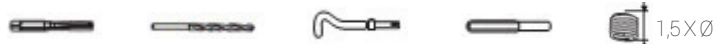

	Ø MASCHIO	PUNTA TRAPANO	POSATORE NUMERO	ROMPI FILETTO	N° PEZZI	ARTICOLO
	6X1	6,3	9	9	20	MF1158.40
	8X1,25	8,3	11	11	20	MF1158.41
	10X1,5	10	13	13	15	MF1158.42
	10X1,25	10,4	13	13	15	MF1158.43
	12X1,75	10,3	15	15	10	MF1158.44
	12X1,5	12,4	15	15	10	MF1158.45
	12X1,25	12,3	15	15	10	MF1158.46
	14X2		16		10	MF1158.47
	14X1,5		16		10	MF1158.48
	16X2		18		10	MF1158.49
	16X1,5		18		10	MF1158.50
	18X2,5		20		5	MF1158.51
	18X1,5		20		5	MF1158.52
	20X1,5		21		5	MF1158.53
22X2,5		22		5	MF1158.54	
22X1,5		22		5	MF1158.55	
24X1,5		23		5	MF1158.56	

KIT RIPRISTINO 5 FILETTI



	Ø MASCHIO	PUNTA TRAPANO	POSATORE NUMERO	ROMPI FILETTO	N° PEZZI	ARTICOLO
	5X0,8	5,2	8	8	25	MF1158.60
	6X1	6,3	9	9	25	
	8X1,25	8,3	11	11	25	
	10X1,5	10,4	13	13	25	
12X1,75	12,4	15	15	10		

FILETTI DA RIPORTO IN ACCIAIO INOX 18/8



	Ø MASCHIO	ARTICOLO				
	5X0,8	AQ1280	AQ1281	AQ1282		
	6X1	AQ1284	AQ1285	AQ1286		
	8X1	AQ1291	AQ1292	AQ1293		
	8X1,25	AQ1287	AQ1288	AQ1289	AQ1290	
	10X1	AQ1300	AQ1301	AQ1302		AQ1304
	10X1,25	AQ1305	AQ1306	AQ1307	AQ1308	AQ1309
	10X1,5	AQ1295	AQ1296	AQ1297	AQ1298	AQ1299
	12X1,25	AQ1315	AQ1316	AQ1317	AQ1318	
	12X1,5	AQ1320	AQ1321	AQ1322	AQ1323	AQ1324
	12X1,75	AQ1310	AQ1311	AQ1312	AQ1313	AQ1314
	14X1,5	AQ1325	AQ1326	AQ1327	AQ1328	
	14X2	AQ1329	AQ1330	AQ1331		
	16X1,5	AQ1341	AQ1343	AQ1345	AQ1347	
	16X2	AQ1333	AQ1335	AQ1337	AQ1339	
ESEMPIO	Ø 6x1 = 6	Ø 6x1,5 = 9	Ø 6x2 = 12	Ø 6x2,5 = 15	Ø 6x3 = 18	

ASSORTIMENTO MASCHI E FILIERE

ASSORTIMENTO MASCHI E FILIERE HSS SPECIALE GARAGE

500x340x60mm.
Kg 7,9

FIAT HSS

DESCRIZIONE		ARTICOLO	
ASSORTIMENTO MASCHI (2PZ) E FILIERE IN HSS DAL 2-18MM. COMPLETO DI GIRAMASCHI E FILIERE 110PZ		MF1158.61	
COMPONENTI	Ø PASSO mm		
 M1 - M10	2,0X0,4	9,0X0,75	12X1
	3,0X0,5	9,0X1	12X1,25
 M5 - M20	4,0X0,7	9,0X1,25	12X1,5
	5,0X0,8	10X0,75	12X1,75
 25,4 x 9,5	6,0X0,75	10X1	14X1
	6,0X1	10X1,25	14X1,25
 38,1 x 12,7	7X0,75	10X1,5	14X1,5
	7,0X1	11X0,75	14X2
 N° 1	8,0X0,75	11X1	16X1
	8,0X1	11X1,25	16X1,5
	8,0X1,25	11X1,5	16X2
		12X0,75	18X1,5

PER GENERARE E RIAVVIARE FILETTI DI:
 FIAT, ALFA ROMEO, LANCIA, VOLSWAGEN, BMW, MERCEDES, FORD, OPEL, G.M,
 PEUGEOT, RENAULT, VOLVO, CITROEN, TOYOTA, NISSAN E HONDA.

ASSORTIMENTO MASCHI E FILIERE AL CROME VANADIUM SPECIALE GARAGE

500x340x60mm.
Kg 7,9

FIAT

DESCRIZIONE		ARTICOLO	
ASSORTIMENTO MASCHI (2PZ) E FILIERE IN CROME VANADIUM DAL 2-18MM. COMPLETO DI GIRAMASCHI E FILIERE 110PZ		MF1158.62	
COMPONENTI	Ø PASSO mm		
 M1 - M10	2,0X0,4	9,0X0,75	12X1
	3,0X0,5	9,0X1	12X1,25
 M5 - M20	4,0X0,7	9,0X1,25	12X1,5
	5,0X0,8	10X0,75	12X1,75
 25,4 x 9,5	6,0X0,75	10X1	14X1
	6,0X1	10X1,25	14X1,25
 38,1 x 12,7	7X0,75	10X1,5	14X1,5
	7,0X1	11X0,75	14X2
 N° 1	8,0X0,75	11X1	16X1
	8,0X1	11X1,25	16X1,5
	8,0X1,25	11X1,5	16X2
		12X0,75	18X1,5

PER GENERARE E RIAVVIARE FILETTI DI:
 FIAT, ALFA ROMEO, LANCIA, VOLSWAGEN, BMW, MERCEDES, FORD, OPEL, G.M,
 PEUGEOT, RENAULT, VOLVO, CITROEN, TOYOTA, NISSAN E HONDA.

DISCHI DA TAGLIO E SMERIGLIO

MOLE DA SMERIGLIO A CENTRO DEPRESSO

	Ø mm	SPESSORE mm	FORO mm	ARTICOLO
	100	6	16	AM1023
	115	6,5	22	AM1026
	230	6	22	AM1031

MOLE DA TAGLIO A CENTRO DEPRESSO

	Ø mm	SPESSORE mm	FORO mm	ARTICOLO
	125	3,2	22	AM1027
	230	3,2	22	AM1040

MOLE DA TAGLIO A CENTRO PIANO

	Ø mm	SPESSORE mm	FORO mm	ARTICOLO
	76	1	10	AM1035.1
	115	1,2	22	AM1037
	115	1,6	22	AM1036
	115	3	22	AM1035
	125	1,2	22	AM1038.125
	125	1,6	22	AM1038.126
	230	2	22	AM1038

MOLE DA TAGLIO A CENTRO PIANO GIOMACAR

	Ø mm	SPESSORE mm	FORO mm	ARTICOLO
	115	1,6	22	AM20000
	115	1	22	AM20001
	125	1,6	22	AM20010
	230	2	22	AM20011

TELE

SMERIGLIO RUOTE LAMELLARI E DISCHI FIBRATI

TELA SMERIGLIO IN FOGLI

	GRANA	ARTICOLO	GRANA	ARTICOLO
	36	AM1001	150	AM1007
	40	AM1002	180	AM1008
	60	AM1003	220	AM1009
	80	AM1004	240	AM1010
	100	AM1005	320	AM1011
	120	AM1006	400	AM1012
DESCRIZIONE TELA SMERIGLIO IN FOGLI AL CORINDONE EXTRAFLESSIBILE 230X280mm				

TELA SMERIGLIO IN ROTOLI

	GRANA	ARTICOLO	GRANA	ARTICOLO
	36	AM1013	100	AM1018
	40	AM1014	120	AM1019
	50	AM1015	150	AM1020
	60	AM1016	180	AM1021
	80	AM1017	220	AM1022
	DESCRIZIONE TELA SMERIGLIO IN ROTOLI AL CORINDONE EXTRAFLESSIBILE H50mm. LUNGHEZZA 25mm			

TELA SMERIGLIO IN ROTOLI

	GRANA	ARTICOLO	GRANA	ARTICOLO
	60	AM1016.01	100	AM1018.01
	80	AM1017.01	120	AM1019.01
DESCRIZIONE TELA SMERIGLIO IN ROTOLI AL CORINDONE EXTRAFLESSIBILE H115mm. LUNGHEZZA 50mm				

RUOTE LAMELLARI AL CORINDONE CON GAMBO

	Ø mm	SPESSORE mm	GRANA	Ø GAMBO mm	ARTICOLO
	30	10	60	6	AM1070
			80		AM1071
			120		AM1072
		20	60		AM1073
			80		AM1074
			120		AM1075
	40	15	60		AM1076
			80		AM1077
			120		AM1078
		20	60		AM1080
			80		AM1081
			120		AM1082

RUOTE LAMELLARI AL CORINDONE CON GAMBO

	Ø mm	SPESSORE mm	GRANA	Ø GAMBO mm	ARTICOLO
	50	20	60	6	AM1083
			80		AM1084
			120		AM1085
		30	60		AM1086
			80		AM1087
			120		AM1088
	60	20	60		AM1089
			80		AM1090
			120		AM1091
		30	60		AM1092
			80		AM1093
			120		AM1094
		40	60		AM1095
			80		AM1096
			120		AM1097

DISCHI FIBRATI AL CORINDONE

	Ø mm	GRANA	ARTICOLO	Ø mm	GRANA	ARTICOLO
	115	24	AM1042.2	125	80	AM1046.1
	115	36	AM1043.2	125	100	AM1047.1
	115	50	AM1044.2	125	120	AM1048.1
	115	60	AM1045.2	180	16	AM1041
	115	80	AM1046.2	180	24	AM1042
	115	100	AM1047.2	180	36	AM1043
	115	120	AM1048.2	180	50	AM1044
	125	24	AM1042.1	180	60	AM1045
	125	36	AM1043.1	180	80	AM1046
	125	50	AM1044.1	180	100	AM1047
	125	60	AM1045.1	180	120	AM1048

DISCHI FIBRATI ALLO ZIRCONIO

	Ø mm	GRANA	ARTICOLO
	180	36	AM1043.1

DISCHI LAMELLARI

DISCHI LAMELLARI PIANI AL CORINDONE

	Ø mm	GRANA	Ø FORO mm	ARTICOLO
	CARATTERISTICHE			
	DISCHI LAMELLARI A LAMELLE INSERITE, AD ALTO RENDIMENTO, ADATTO PER LAVORAZIONI DI CARPENTERIA PESANTE.			
	115	36	22	AM1050
		40		AM1051
		50		AM1052
		60		AM1053
80		AM1054		
100	AM1055			
* GHIERA SVASATA DI FISSAGGIO M14			AM1056.3	

DISCHI LAMELLARI PIANI AL CORINDONE

	Ø mm	GRANA	Ø FORO mm	ARTICOLO
	115	40	22	AM1051.1
		60		AM1053.1
		80		AM1054.1
		120		AM1056
CARATTERISTICHE				
DISCHI LAMELLARI A LAMELLE APPLICATE, ADATTO PER LAVORAZIONI DI CARPENTERIA.				

IN ESAURIMENTO

DISCHI LAMELLARI PIANI AL CORINDONE GIOMACAR

	Ø mm	GRANA	Ø FORO mm	ARTICOLO
	115	40	22	AM20006
		60		AM20007
		80		AM20008
		120		AM20009
CARATTERISTICHE				
DISCHI LAMELLARI A LAMELLE APPLICATE, ADATTO PER LAVORAZIONI DI CARPENTERIA.				

DISCHI LAMELLARI PIANI ALLO ZIRCONIO

	Ø mm	GRANA	Ø FORO mm	ARTICOLO
	115	40	22	AM1051.01
		60		AM1053.01
		80		AM1054.01
		120		AM1056.02
CARATTERISTICHE DISCHI A LAMELLA APPLICATA ADATTI PER LA LAVORAZIONE DELL'ACCIAIO INOX				

DISCHI LAMELLARI PIANI ALLO ZIRCONIO GIOMACAR

	Ø mm	GRANA	Ø FORO mm	ARTICOLO
	115	40	22	AM20002
		60		AM20003
		80		AM20004
		120		AM20005
CARATTERISTICHE DISCHI A LAMELLA APPLICATA ADATTI PER LA LAVORAZIONE DELL'ACCIAIO INOX				

DISCHI LAMELLARI PIANI ALLO ZIRCONIO

<p>STROBO</p>	Ø mm	GRANA	Ø FORO mm	ARTICOLO
	115	40	14	AM1051.2
		60		AM1053.2
		80		AM1054.2
		120		AM1056.2
CARATTERISTICHE DISCHI LAMELLARI A LAMELLE APPLICATE, ADATTO PER LAVORAZIONI DI CARPENTERIA CON LE SPECIALI ASOLE SUL PLATORELLO PERMETTONO LA VISIONE DELLA LAVORAZIONE.				

VERSIONE 1 07/2015 * Le marche utilizzate in questo catalogo, così come i riferimenti originali inclusi, servono unicamente per aiutare ad identificare l'articolo. Tutti i componenti citati sui nostri cataloghi e listini non sono originali ma perfettamente compatibili e intercambiabili.

DISCHI RESINATI CON VELCRO

DISCHI IN CARTA RESINATA PESANTE AL CORIDONE CON SUPPORTO VELCRATO

DISCO VELCRATO SENZA FORI

	Ø mm	GRANA	NUMERO FORI	ARTICOLO
	150	40	0	AM1049.05
		60		AM1049.06
		80		AM1049.07
		100		AM1049.08
		120		AM1049.09

DISCO VELCRATO 6 FORI

	Ø mm	GRANA	NUMERO FORI	ARTICOLO
	150	40	6	AM1049.10
		60		AM1049.11
		80		AM1049.12
		100		AM1049.13
		120		AM1049.14

DISCO VELCRATO 8 FORI

	Ø mm	GRANA	NUMERO FORI	ARTICOLO
	125	40	8	AM1049
		60		AM1049.01
		80		AM1049.02
		100		AM1049.03
		120		AM1049.04

DISCO VELCRATO 8 FORI + 1 FORO CENTRALE

	Ø mm	GRANA	NUMERO FORI	ARTICOLO
	150	40	8+1	AM1049.15
		60		AM1049.16
		80		AM1049.17
		100		AM1049.18
		120		AM1049.19

PLATORELLI VELCRATI

<p>ADATTI PER LEVIGARE ROTORBITALI E ORBITALI</p>	Ø mm	Ø FILETTO mm	NUMERO FORI	ARTICOLO
	125	5/16" - M8	8	AM1049.20
	150		0	AM1049.22
			6	AM1049.22
8+1			AM1049.23	

MOLE ROTATIVE AL CORINDONE NOBILE

MOLE ROTATIVE AL CORINDONE GAMBO Ø 6 MM

CILINDRICHE

	Ø mm	SPESSORE mm	ARTICOLO
	6	10	AM1098.01
	10	10	AM1098.02
	10	20	AM1098.03
	10	32	AM1098.04
	13	20	AM1098.041
	16	16	AM1098.05
	16	20	AM1098.06
	16	32	AM1098.07
	20	20	AM1098.08
	20	40	AM1098.09
	25	25	AM1098.10
32	32	AM1098.11	
40	40	AM1098.12	

OGIVA

	Ø mm	SPESSORE mm	ARTICOLO
	5	10	AM1098.20
	8	16	AM1098.21
	13	20	AM1098.23
20	32	AM1098.24	

CILINDRICHE PIATTA

	Ø mm	SPESSORE mm	ARTICOLO
	13	3	AM1098.30
	16	4	AM1098.31
	20	6	AM1098.32
	25	10	AM1098.33
	32	8	AM1098.34
32	20	AM1098.35	

CONICA

	Ø mm	SPESSORE mm	ARTICOLO
	15	30	AM1098.41
	16	40	AM1098.42
	20	32	AM1098.43
25	40	AM1098.44	

SFERA

	Ø mm	ARTICOLO
	6	AM1098.50
	8	AM1098.51
	10	AM1098.52
	13	AM1098.53
	16	AM1098.54
	20	AM1098.55
	25	AM1098.56
	32	AM1098.57

MANICOTTI MOLE DA BANCO / LAME BIMETALLICHE

	MANICOTTI GR 80		PORTA MANICOTTI	
	Ø mm	ARTICOLO	Ø mm	ARTICOLO
	10X10	AM1099	10X10	AM1099.11
	10X20	AM1099.01	10X20	AM1099.12
	13X25	AM1099.02	13X25	AM1099.13
	15X30	AM1099.03	15X30	AM1099.14
	20X30	AM1099.04	20X30	AM1099.15
	22X20	AM1099.05	22X20	AM1099.16
	25X25	AM1099.06	25X25	AM1099.17
	30X20	AM1099.07	30X20	AM1099.18
	30X30	AM1099.08	30X30	AM1099.19
	45X30	AM1099.09	45X30	AM1099.20
	60X30	AM1099.10	60X30	AM1099.21

MOLE DA BANCO AL CORINDONE ROSA

	Ø mm	SPESSORE mm	Ø FORO mm	ARTICOLO
	150	20	16	AM1175.06
	200	25	20	AM1175.07
PER AFFILATURE UTENSILI IN ACCIAIO RAPIDO E TEMPERATO				

MOLE DA BANCO AL CARBURO DI SILICIO VERDE

	Ø mm	SPESSORE mm	Ø FORO mm	ARTICOLO
	150	20	16	AM1175.09
	200	25	20	AM1175.05
PER AFFILATURE UTENSILI IN METALLI DURI				

LAME SEGHETTO A MANO BIMETALLICHE

HSS-BIMETAL	DESCRIZIONE	ARTICOLO
 <p>KRINO BI-HSS Superflex</p> <p>HRC 64 HRC 38÷40</p> <p>Super Flex</p>	LAMA SEGHETTO BIMETALLICA SUPER FLESSIBILE 24 DENTI 300X13X0,66mm	AM1138

SPAZZOLE IN ACCIAIO CON GAMBO E CIRCOLARI

SPAZZOLA TAZZA CON GAMBO

	Ø GAMBO mm	Ø mm	ARTICOLO
	6X25	50	AM1168
		60	AM1169
		70	AM1170

SPAZZOLA A TAZZA FILETTATA

	Ø FILETTO mm	Ø mm	ARTICOLO
	14	80	AM1171
		100	AM1172

SPAZZOLA A PENNELLO

	Ø FILETTO mm	Ø mm	ARTICOLO
	6X20	15	AM1164
	6X18	20	AM1165
		25	AM1166
		30	AM1167

SPAZZOLA A PENNELLO GAMBO LUNGO IN ACCIAIO OTTONATO

	Ø FILETTO mm	Ø mm	ARTICOLO
	6X80	18	AM1175

SPAZZOLA A PENNELLO GAMBO E FILI RITORTI

	Ø FILETTO mm	Ø mm	ARTICOLO
	6X80	18	AM1175.01

SPAZZOLA CIRCOLARE CON GAMBO E FILI RITORTI

	Ø FILETTO mm	Ø mm	ARTICOLO
	6X25	95	AM1175.02

SPAZZOLA CIRCOLARE FILETTATA CON FILTRI RITORTI

	Ø FILETTO mm	Ø mm	ARTICOLO
	14	95	AM1175.03

SPAZZOLA CIRCOLARE CON GAMBO

	Ø FILETTO mm	Ø mm	ARTICOLO
	6X25	30	AM1160
		40	AM1161
		50	AM1162
		60	AM1163

SPAZZOLA CIRCOLARE CON GAMBO

	Ø mm	SPESSORE mm	Ø FORO mm	ARTICOLO
	150	20	38	AM1173
	200	23		AM1174

CON ADATTATORI DA 16-20-25mm

SPAZZOLA MANUALE CON FILI OTTONATI

	DESCRIZIONE	ARTICOLO
	<p>SPAZZOLA IN ACCIAIO OTTONATO DA 236X135mm</p>	<p>AM1175.04</p>

VERSIONE 1 07/2015 * Le marche utilizzate in questo catalogo, così come i riferimenti originali inclusi, servono unicamente per aiutare ad identificare l'articolo. Tutti i componenti citati sui nostri cataloghi e listini non sono originali ma perfettamente compatibili e intercambiabili.